



Interreg North-West Europe GenComm

European Regional Development Fund

GenComm Workshop *Saarbrücken, Germany*

AGENDA: Block I

13:30 Registration

14:00 Welcome & Lead Partner Greeting (Bodo Groß/Paul McCormack)

14:10 Message from Saarland State Secretary Jürgen Barke

14:30 Investment WPs

- WP.I3 (VIRIDIAN)
- WP.I1 (PEC/INSA ROUEN/ENSICAEN)
- WP.I2 (IZES)

15:00 Keynote Speaker Axel Rücker, Head of Sub-project Component Control & Technology Management, Department of Hydrogen and Fuel Cells, BMW Group

15:30 Hydrogen for Mobility Applications Q&A

Introduction to GenComm

*Paul McCormack
Project Leader, BelfastMet*





Belfast Met

Company Description

- Belfast Met is the largest further and Higher Education College in Northern Ireland and one of the largest in the UK.
- Its focus for the future is to support the development of Belfast by providing education, training and skills development to enhance individual, community and economic prosperity.
- The College has already built an excellent reputation with employers for offering relevant, high quality learning. Now it is aimed to build on this by focusing on developing long-term mutually beneficial partnerships and becoming recognised as an expert in key and emerging growth areas.

Interreg North-West Europe GenComm

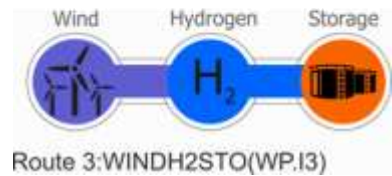
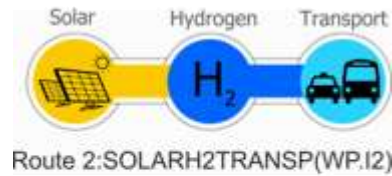
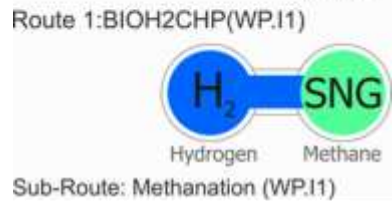
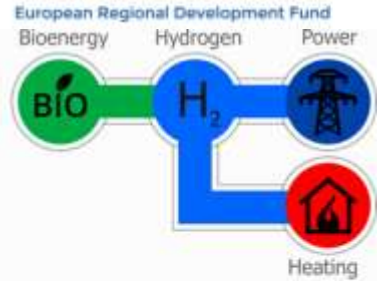

WP.I1
Pilot Plant: Western Isles, UK
(Medium Scale, 225 KW)

WP.I1.1
Pilot Plant: Rouen, FR
(Lab Scale)

WP.I2
Pilot Plant: Saarbrücken, DE
(Small Scale, 35 KW)

WP.I3
Pilot Plant: Ballymena, NI
(Large Scale, ~500 KW)

WP.T1: Hydrogen Value Chain
(Technical Model)

IOM **Outputs**

Integrated Overall Model of a community scale H₂ value chain.

FDMM **Outputs**

Financial Decision Making of a community scale H₂ value chain.

WP.T2: Hydrogen Value Chain
(Financial Model)

Project Overview

- INTERREG NWE
- ERDF Funding €5.63 m
- Total Budget €9.39 m
- Timeline: (2016) 2017-2020
- 10 Partners
- UK/IE/DE/FR/BE

WP. LTE: Long Term Effects (DST)

DST **Outputs**

Decision Support Tool to forecast implementation projects.

Message from Saarland State Secretary

Jürgen Barke
Staatssekretär/State Secretary

Investment Work Package, WP.I3

Wind to H₂ storage and products

Mark Welsh

energia

VIRIDIAN

Renewables

Owned Renewables Assets

- Comprises direct investments in c.300MW of operating, under-construction and development wind farm projects, including 95MW Meenadreen Extension, one of Ireland's largest operating Wind farms.
- Actively progressing a medium term pipeline in Ireland
- Growth consistent with Ireland's commitment to renewables (40% by 2020)

Renewables PPAs

- 1.2GW of operational offtake capacity, includes 900MW of PPAs with independent generators
- 15-year contracts with renewable generators (predominantly wind farms)
- >25% market share in all-island wind PPA market
- Material PPA offtake portfolio underpinned by renewable support (REFIT and RO)

Flexible Generation

Thermal Generation

- Huntstown 1 and 2
- Two modern, efficient and flexible CCGTs
- 747 MW capacity
- c.11% of all-island peak electricity demand
- c.95% availability since COD

Regulated Power Procurement ("PPB")

- Regulated procurement of electricity in NI
- 600MW capacity under contract
- Pass-through of operating costs

Supply

Competitive Retail



- Established market shares in the market segments in which it participates
- Business electricity: 55,100 customer sites across NI and RoI
- RoI unregulated natural gas: 4,464 customer sites
- Recent successful entry into RoI domestic market: 121,700 electricity and gas customer sites

Regulated and Competitive Retail



- Market leader in NI domestic electricity with a 59% market share (by connections)
- NI domestic electricity: 468,000 customer sites (1st in NI)
- NI business electricity: 23,000 customer sites (1st in NI)
- Growing unregulated income including c300MW of renewable PPAs (included in 1.2GW Viridian total)

Viridian's Owned Wind Generation Assets

Operational (Wholly-owned)		
1	Hollyford	9.0
2	Thornog	20.0
3	Clondemot	2.3
4	Lisglass	2.3
5	Long Mountain	27.6
6	Meenadreen	95.0
7	Glenbuck	9.4
8	Gortfinbar	15.0
9	Eshmore	7.1
10	Altamuskin	14.1
Total		201.6
Under Construction		
11	Rathsherry	21.2
12	Comavarrow	36.0
13	Slieveglass	6.9
14	Teiges	11.0
Total		75.1
Minority Owned (Operational)		
15	Arigna	1.2
16	Drumlough Hill	1.2
17	Largan Hill	1.5
18	Meenadreen	0.9
19	Geevagh	1.3
20	Drumlough Hill Ext	2.6
21	Corkermore	2.5
22	Caherdowney	2.3
23	Church Hill	3.7
24	Crighshane	6.4
Total		23.5

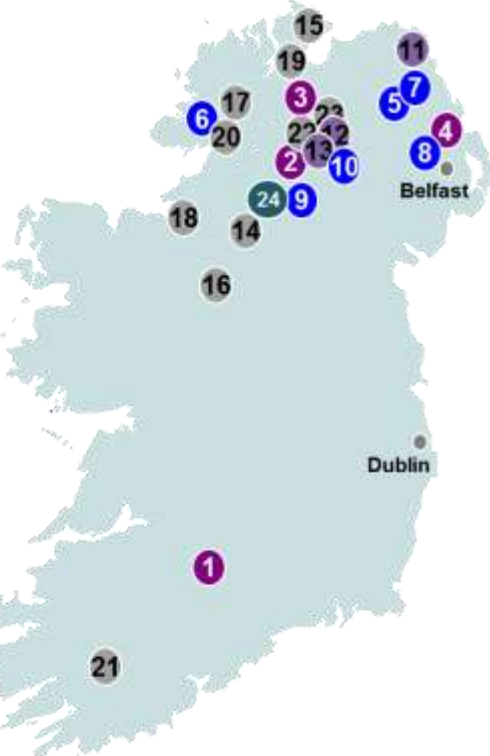

Energia & PowerNI PPAs – 1.2GW



Current Contracted Wind PPAs
c.1035MW

Other Technology PPAs
165 MW



95MW Meenadreen



27MW Long Mountain

- Viridian has committed c.€500m of investment in its wholly owned portfolio since 2008
- Viridian has also underpinned a further €600m investment in Irish renewable energy projects through offtake contracts (“PPAs”) which support the financing of independent project owners

Source: VIRIDIAN Group

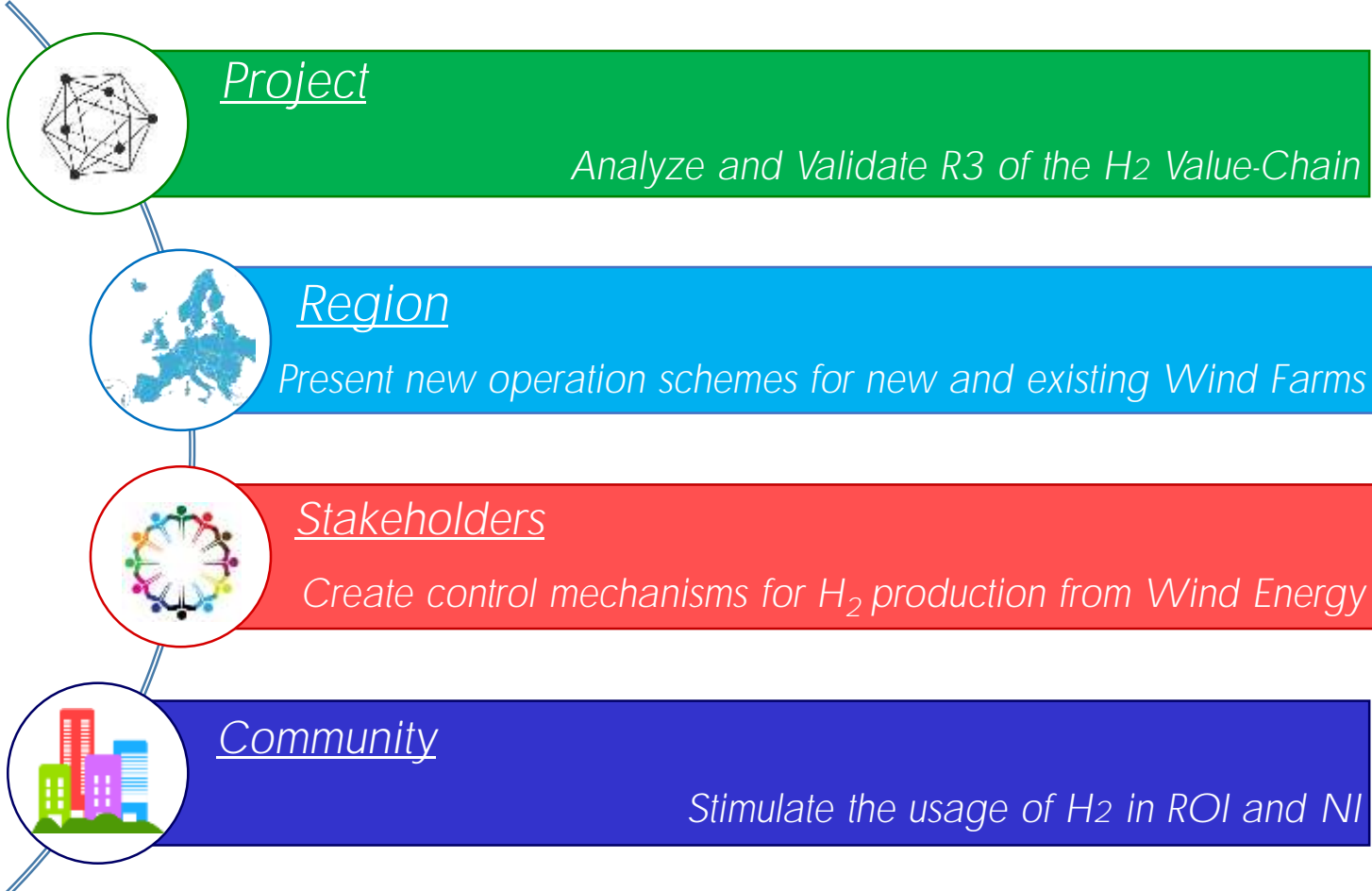

Overview to WP.13

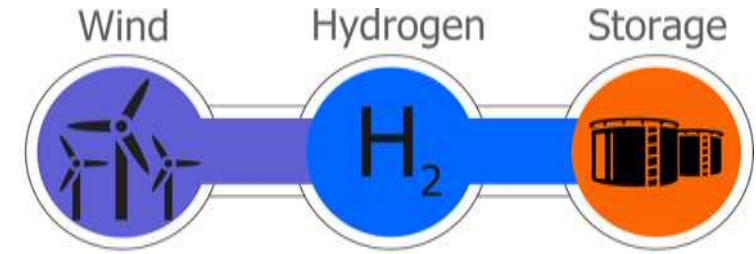

Route 3: WINDH2STO(WP.13)

Route Ahead



*Design, Planning and Permits
 March 2018*

*Procurement and Implementation
 November 2018*

*Operation and Data Analysis
 November 2019*

WP.I3 WINDH2STO

Pilot Scheme

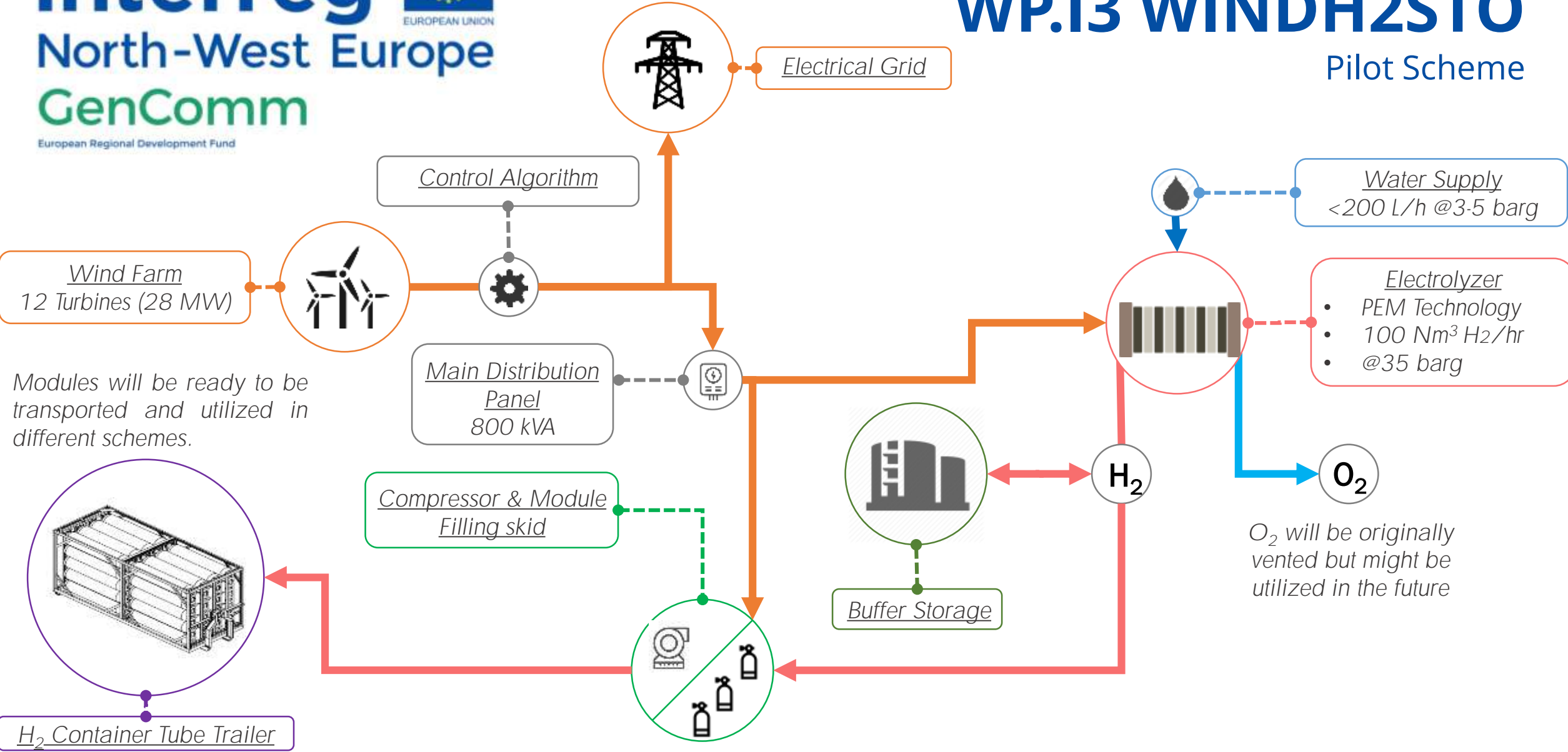

Modules will be ready to be transported and utilized in different schemes.

O₂ will be originally vented but might be utilized in the future

WP.I3 Location

Context in Northern Ireland (NI) Communities

NI Renewable Generation technology Mix



- Wind Energy capacity progress:
 - 850 MW (2016)
 - 1100 MW (September 2017)
- Current RES: 23% (20% Wind), RES 2020: 40%

Curtailment in NI

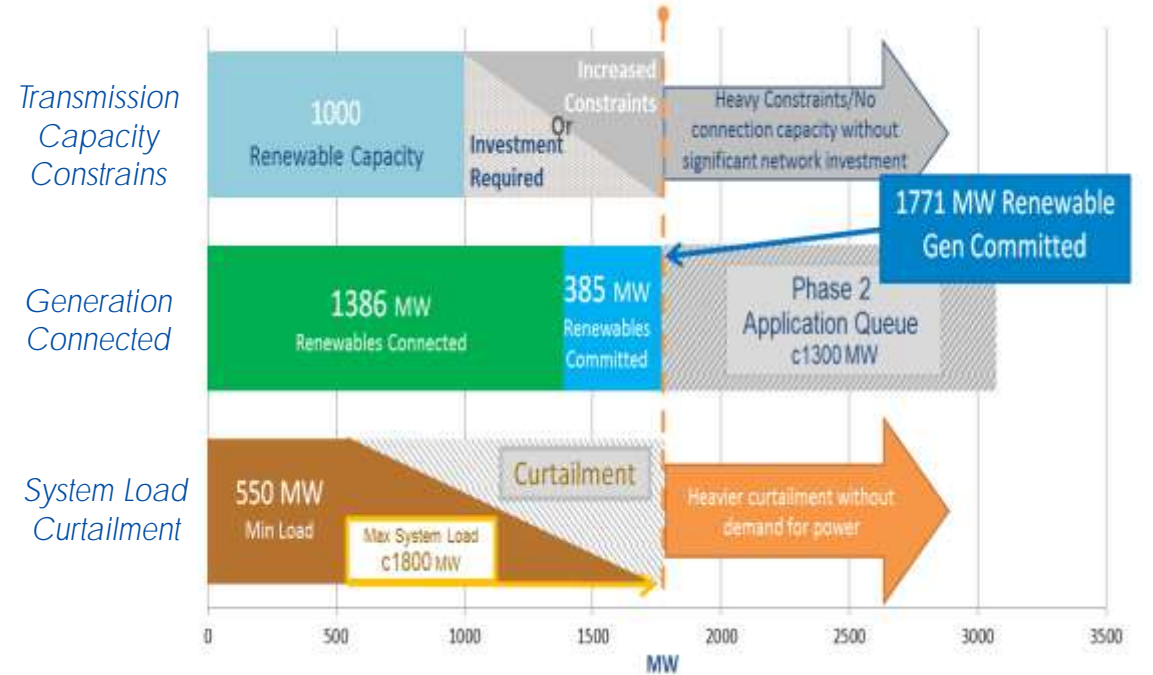

- Northern Ireland Renewable Obligation (NIRO) is now closed to new developments.

Source: Northern Ireland Electricity Networks

WP.13 Location

Wind Park and Plant Distribution



Long Mountain Wind Park Location

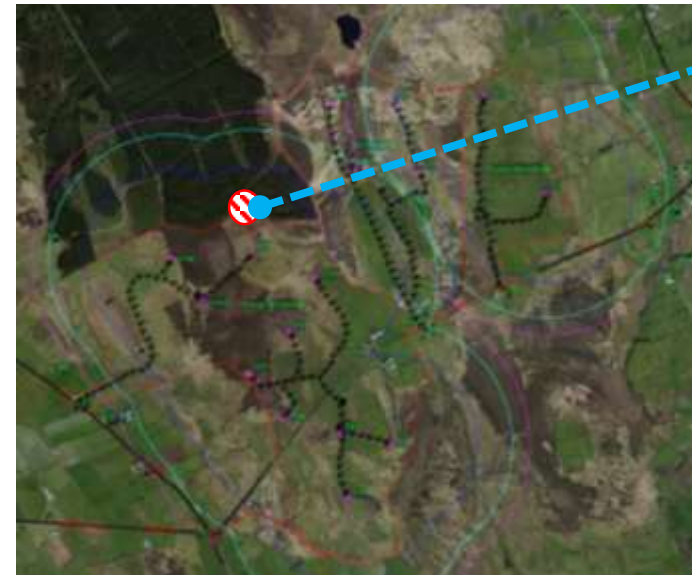

Hydrogen Production Location



- Location:
 Long Mountain Wind Park
 NW from Ballymena, County Antrim NI
- Wind Park Characteristics
 12 ENERCON E70 E4 Turbines
 (28 MW)
- Components:
 - Electrolyzer
 - Mobile Trailers
 - Compressor Bank
 - Buffer Tank
 - Coolers

Source: GOOGLE Maps and VIRIDIAN Group

Interreg



EUROPEAN UNION

North-West Europe

GenComm

European Regional Development Fund

Thank You!

Investment Work Package, WP.I1

*BioEnergy to H₂ for combined Heat and Power
Methanation Sub-Route*

Vincenzo Ortisi (PEC) and Lokmane Abdelouahed (INSA ROUEN)



LSPC
Laboratoire
de sécurité
des procédés
chimiques

INSA

INSTITUT NATIONAL
DES SCIENCES
APPLIQUÉES
ROUEN



ENSICAEN
ÉCOLE PUBLIQUE D'INGÉNIEURS
CENTRE DE RECHERCHE



Pure Energy Centre

Company Description

- The Pure Energy Centre is a company with expertise on Hydrogen and Renewable Energy technologies
- The PEC supply renewable energy system including solar wind and biomass both for grid and off grid systems.
- The PEC has a worldwide delivering proof of Hydrogen refuelling station for automotive application, such as Bus , vehicle at 350 and 700 bar.
- The PEC is specialised on supply of Hydrogen, Oxygen and Nitrogen generator, compressor, storage and gas purification.
- The PEC is worldwide renown for training course on RE energy and Hydrogen technologies.

Work Package Leader

Overview



INSA ROUEN ENSICAEN

INSA Rouen - LSPC

(Laboratory of Safety and Chemical Processes)

ENSICAEN-LCS

- INSA Rouen Normandie and ENSICAEN are two of the 210 public engineering schools accredited for delivering the engineer title in France.
- INSA Rouen formation is in the field of Mechanical, Chemical, Civil, Mathematical engineering, Risks assessment, Computer engineering with more than 450 graduated per year.
- ENSICAEN formation is in the field of Chemistry.
- LSPC from INSA Rouen is a Chemical Engineering Laboratory, specialized in Safety, CO2 capture and valorization, Biomass valorization, and Process intensification by microwaves.
- LCS from ENSICAEN is specialized in catalysis and Infrared Spectroscopy.

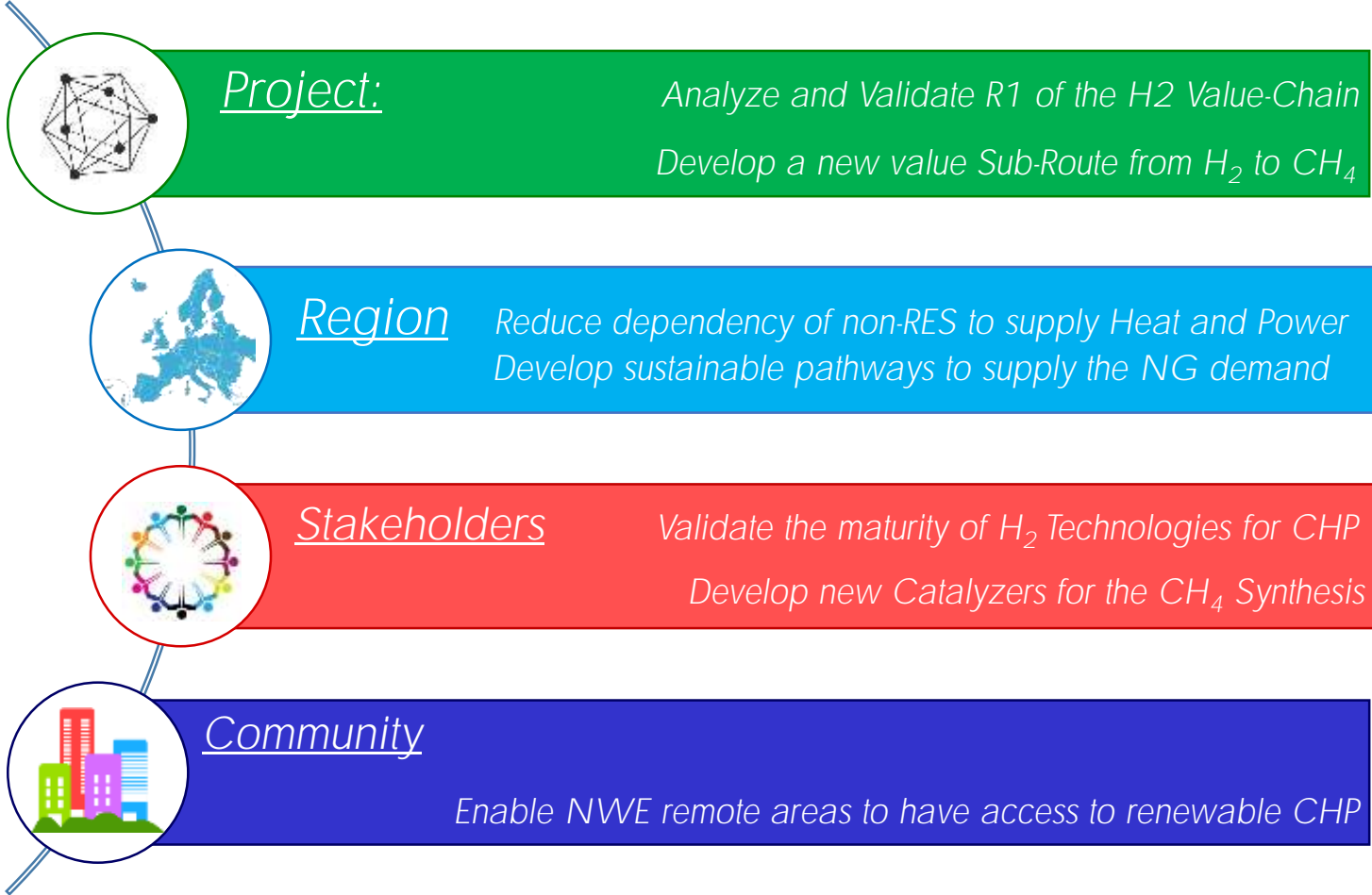

Overview to WP.I1

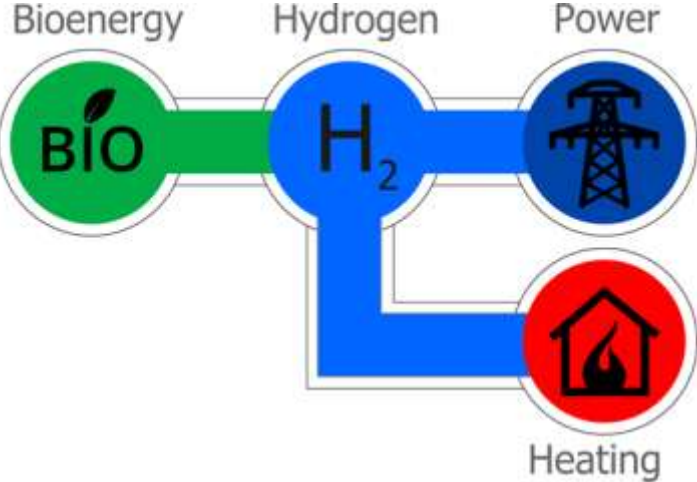

Route 1: BIOH₂CHP (WP.I1)

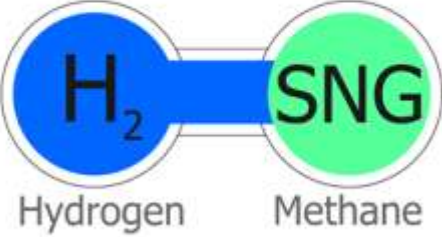

Sub-Route: Methanation (WP.I1)

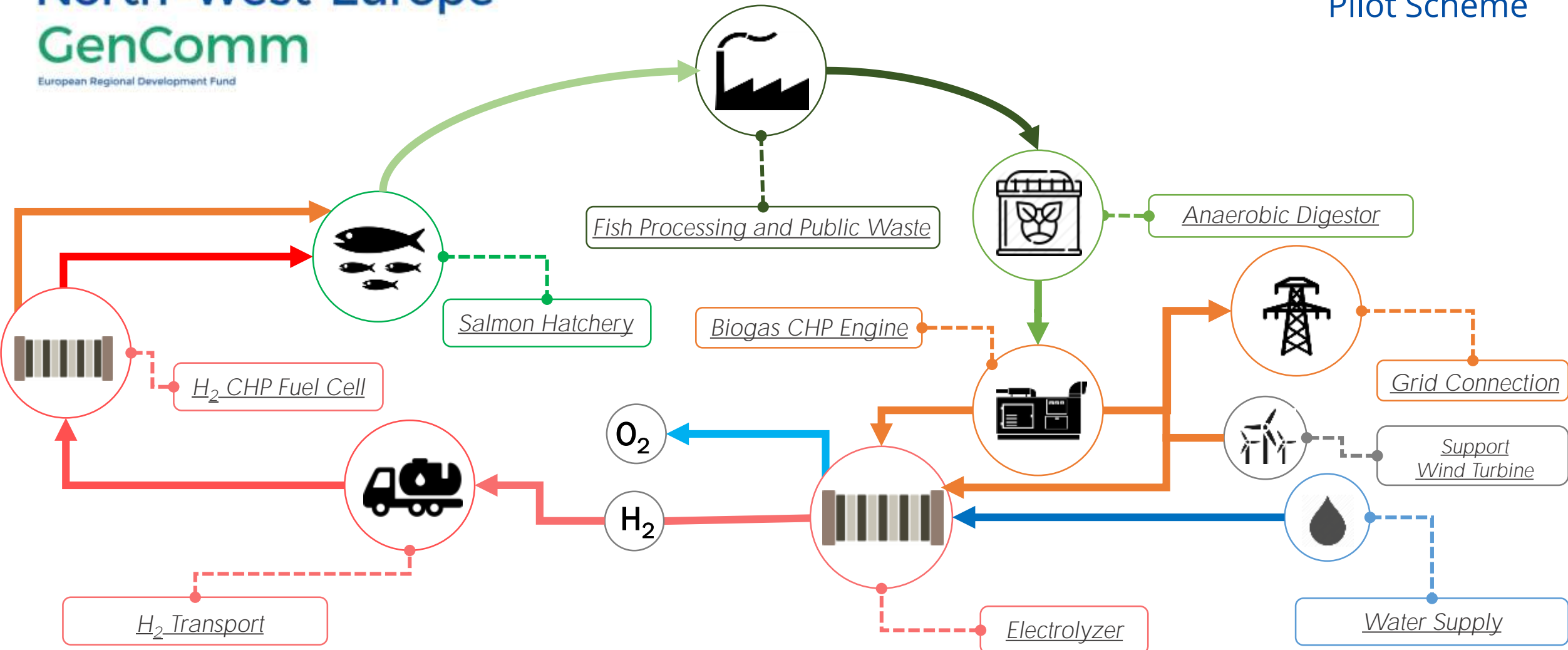

WP.I1 Methanation

Development Plan

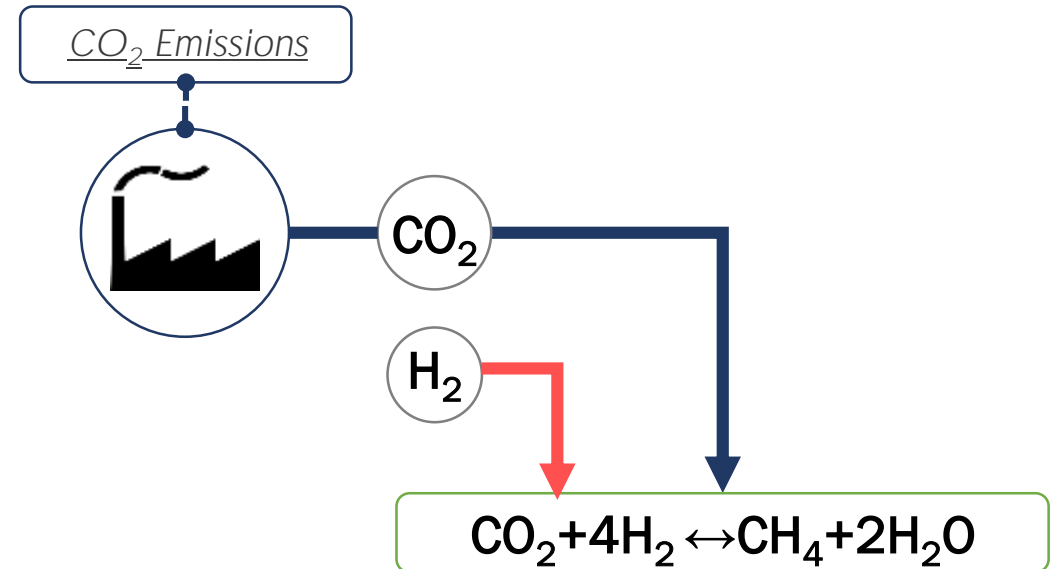
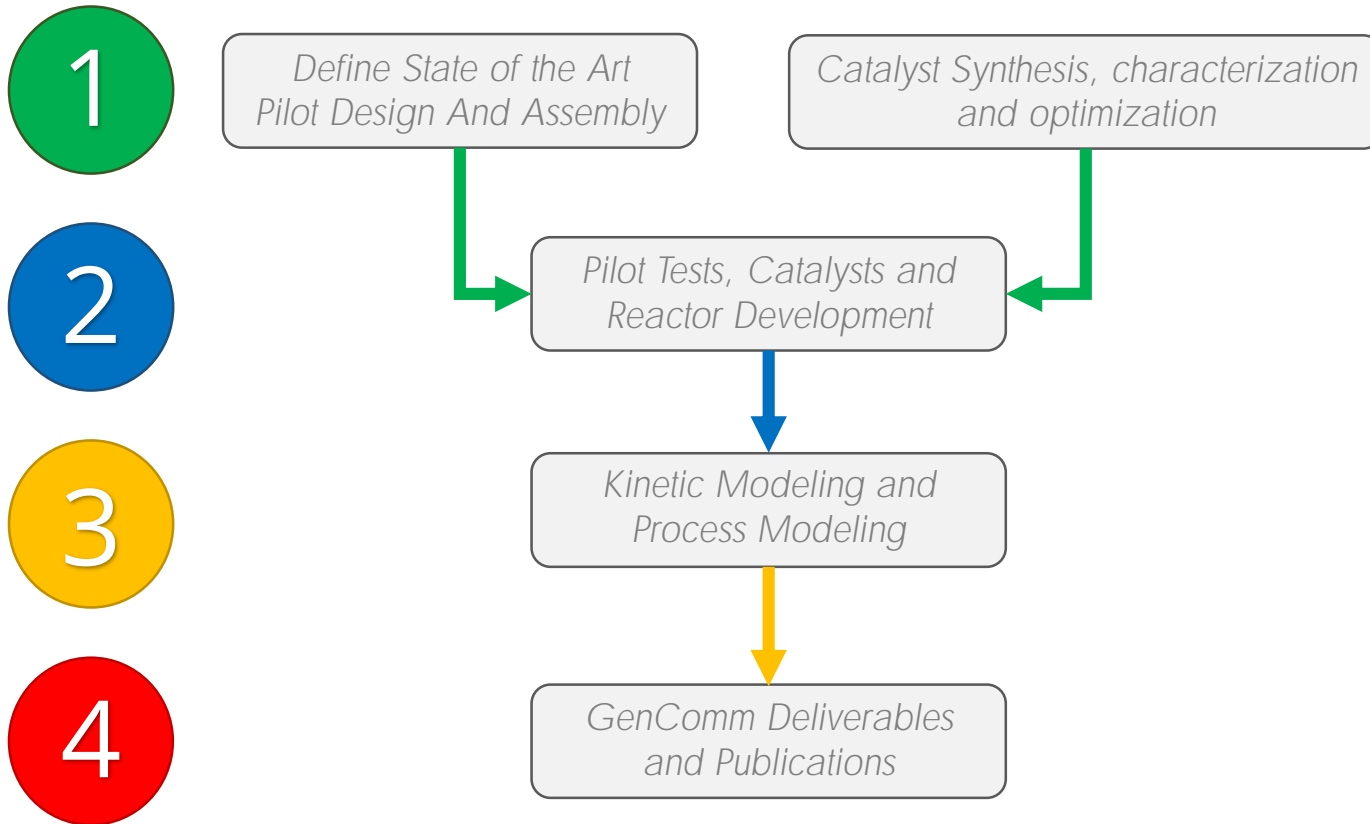

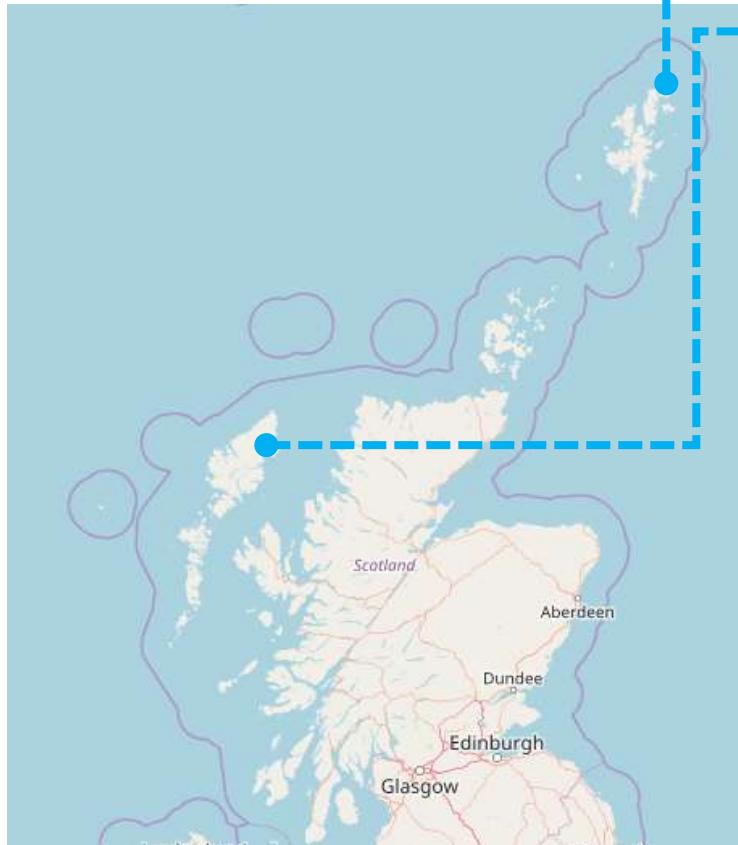

Stornoway Waste Plant & PEC Location

Shetland Islands
 (PEC Location)
 Stornoway Waste Plant



- Location:
 Stornoway, Isle of Lewis, Scotland
- Stornoway Plant Characteristics
 - Wind Turbine 300 kW
 - Waste Collection Facility
 - Anaerobic Digester
 Biogas Yield: 448,312 m³/year
 - Hydrogen Production Plant
 Alkaline Electrolyzer
 - Storage and Transport Skid

WP.I1 Location

Stornoway Waste Plant (Existing)



Stornoway AD Plant



Stornoway Hydrogen Plant Plant

Source: Open Source Maps and PEC



INSA Rouen, Rouen France



ENSICAEN, Caen France

WP.I1 Location

Methanation

SCOPE

- Location:
 - Rouen, Normandie, France*
 - Caen, Normandie, France*
- Aspects Studied
 - *Thermodynamics*
 - *Catalysts*
 - *Kinetics and Mechanisms*
 - *Processes and Reactors*
- Components:
 - *Chromatograph*
 - *Flowmeters, pressure and temperature sensors*
 - *IR Analyzers*
 - *Infrared Spectrometers*
 - *Lab-Scale Reactors*

Source: INSA ROUEN and ENSICAEN

Interreg



EUROPEAN UNION

North-West Europe

GenComm

European Regional Development Fund

Thank You!

Investment Work Package, WP.12

Solar Power to H₂ for Sustainable Mobility

Alejandro Tristán



Overview to WP.I2

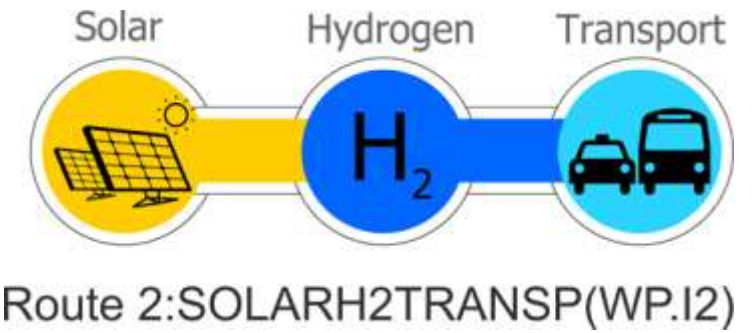
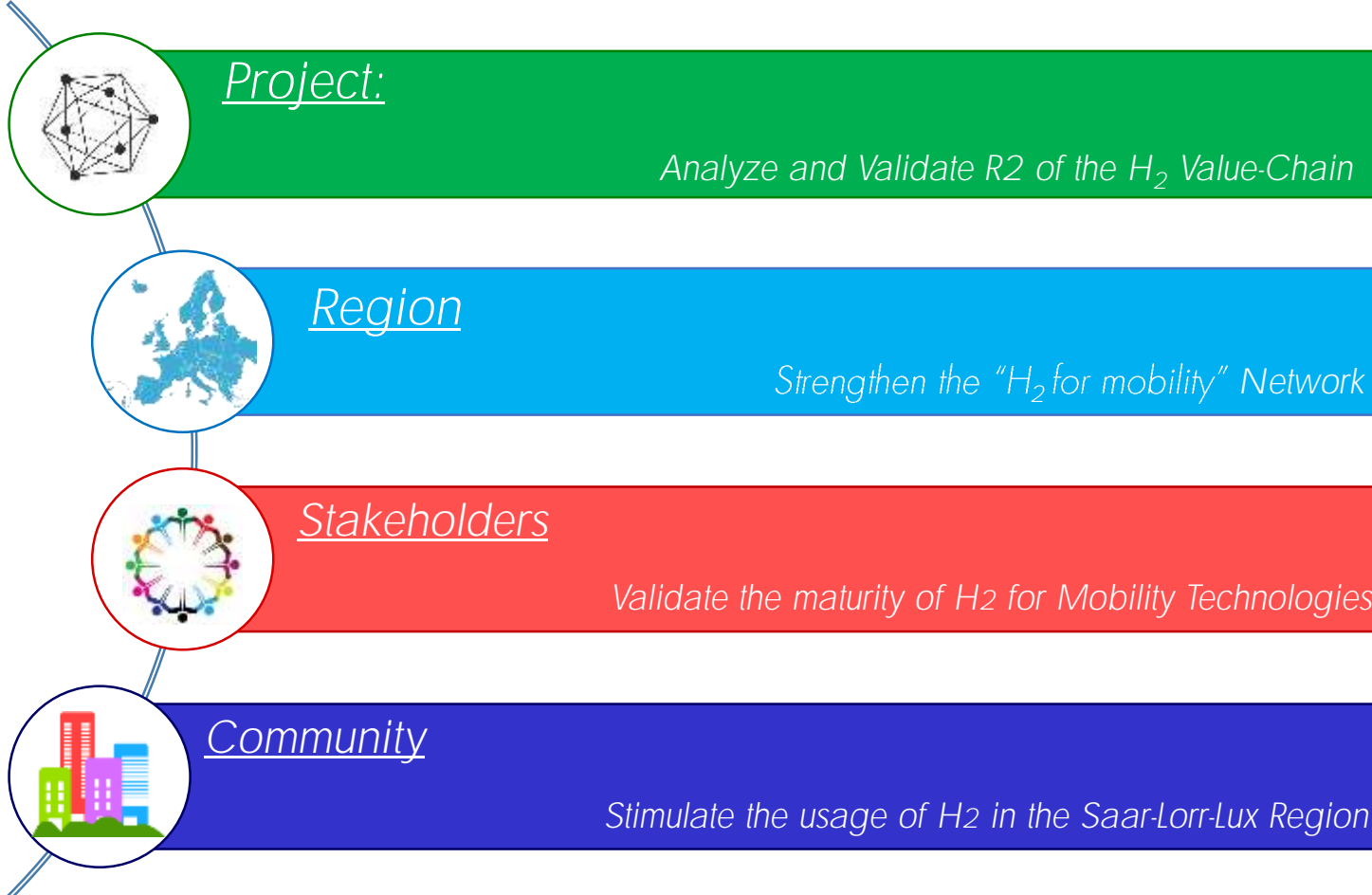

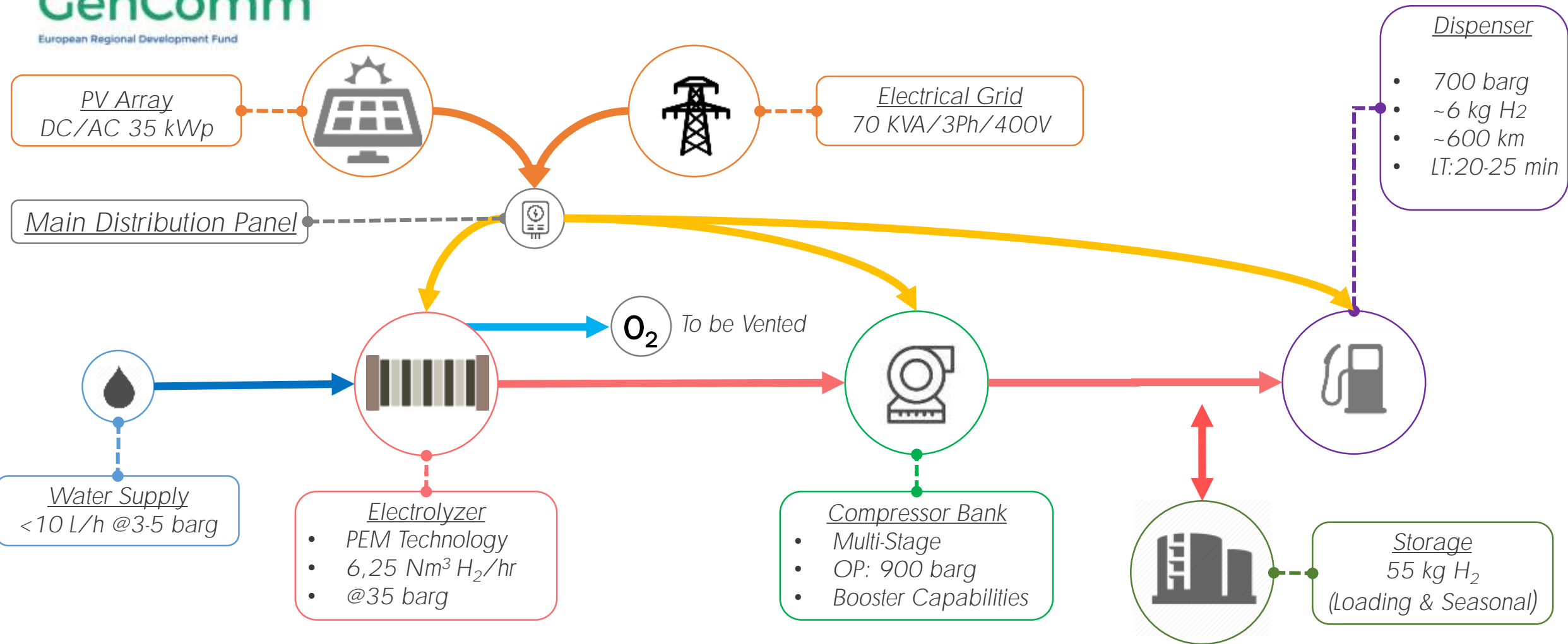

WP.I2 Location

Hydrogen Refueling Station



Station
(Incl. security clearance)

IZES GmbH

PV Array



- *Location: Innovation Campus Saar
Saarbrücken, Germany*
- *Semi-Autonomous Operation (PV Array)*
- *700 barg loading*
- *Seasonal and Loading Storage (1 Vehicle)**
- *Peak Production Expansion*
- *Water Treatment Unit*
- *Containerized Solution*
- *Monitoring and Plant Management System*

Location of the H₂ Refueling Station

Source: GOOGLE Maps

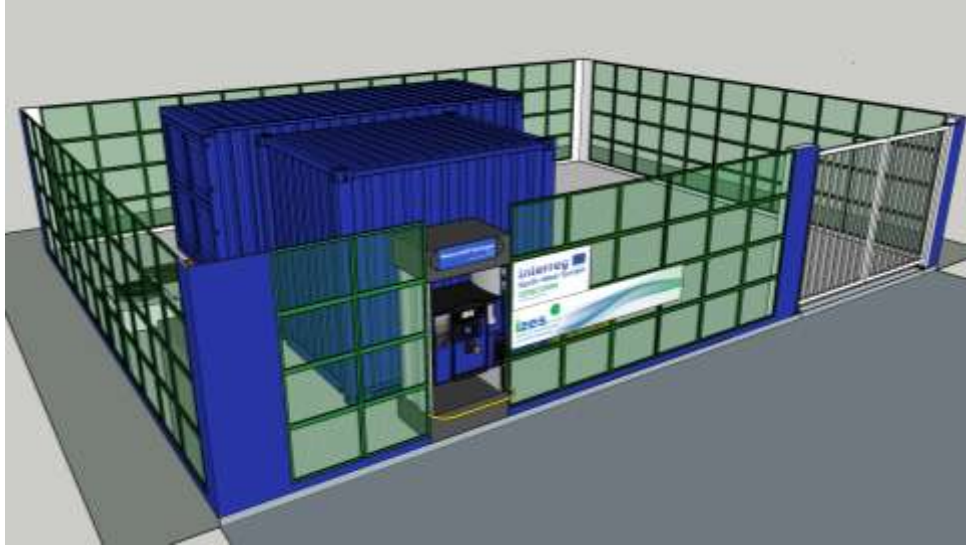

H₂ Refueling Station (ISO View and Distribution)

Source: GOOGLE Maps

18/12/2017

WP.I2 Location

Scope of Work

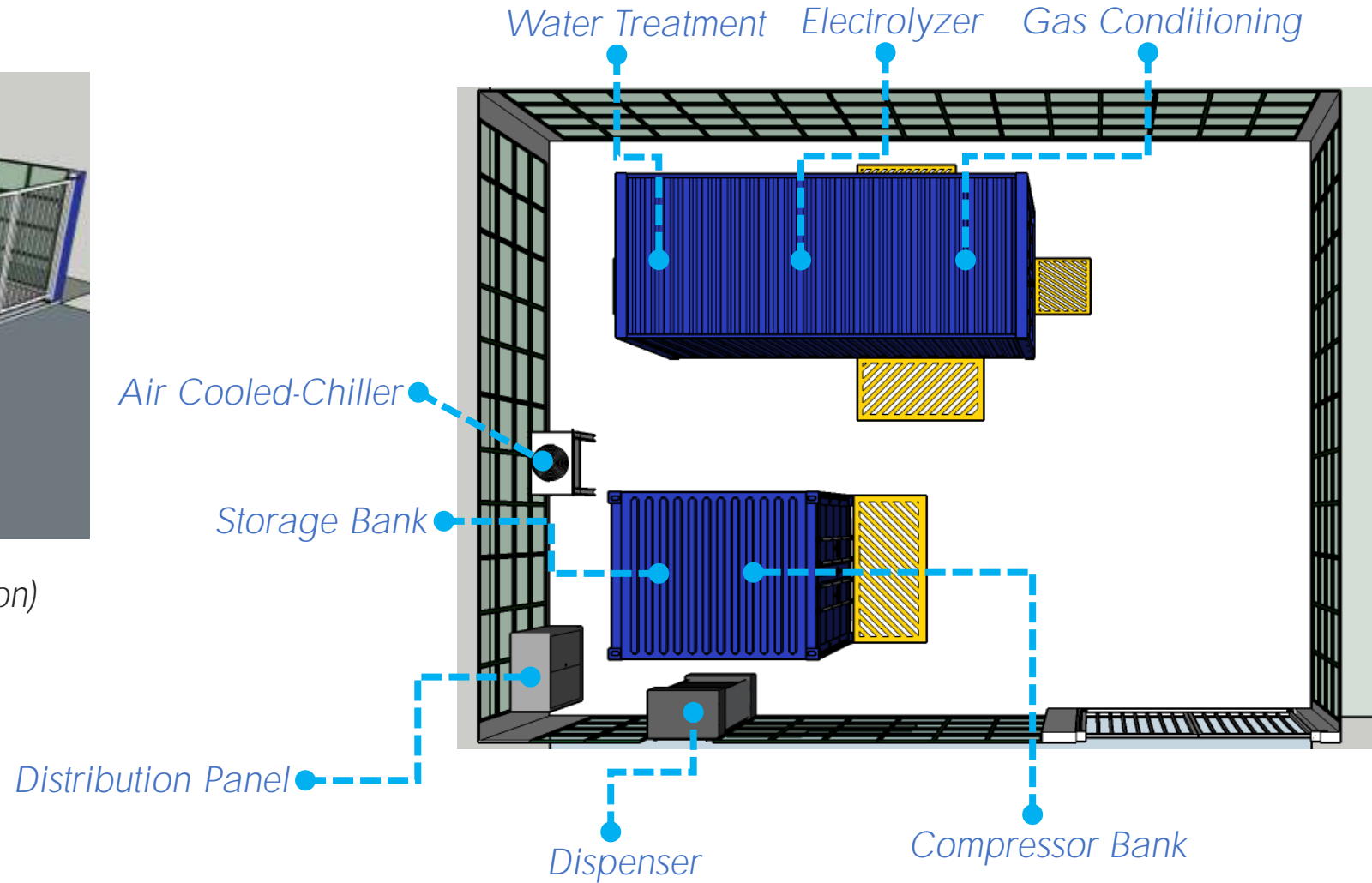

GenComm Workshop

27

WP.I2 Local Impact

Advantages of developing WP.I2 in Saarland

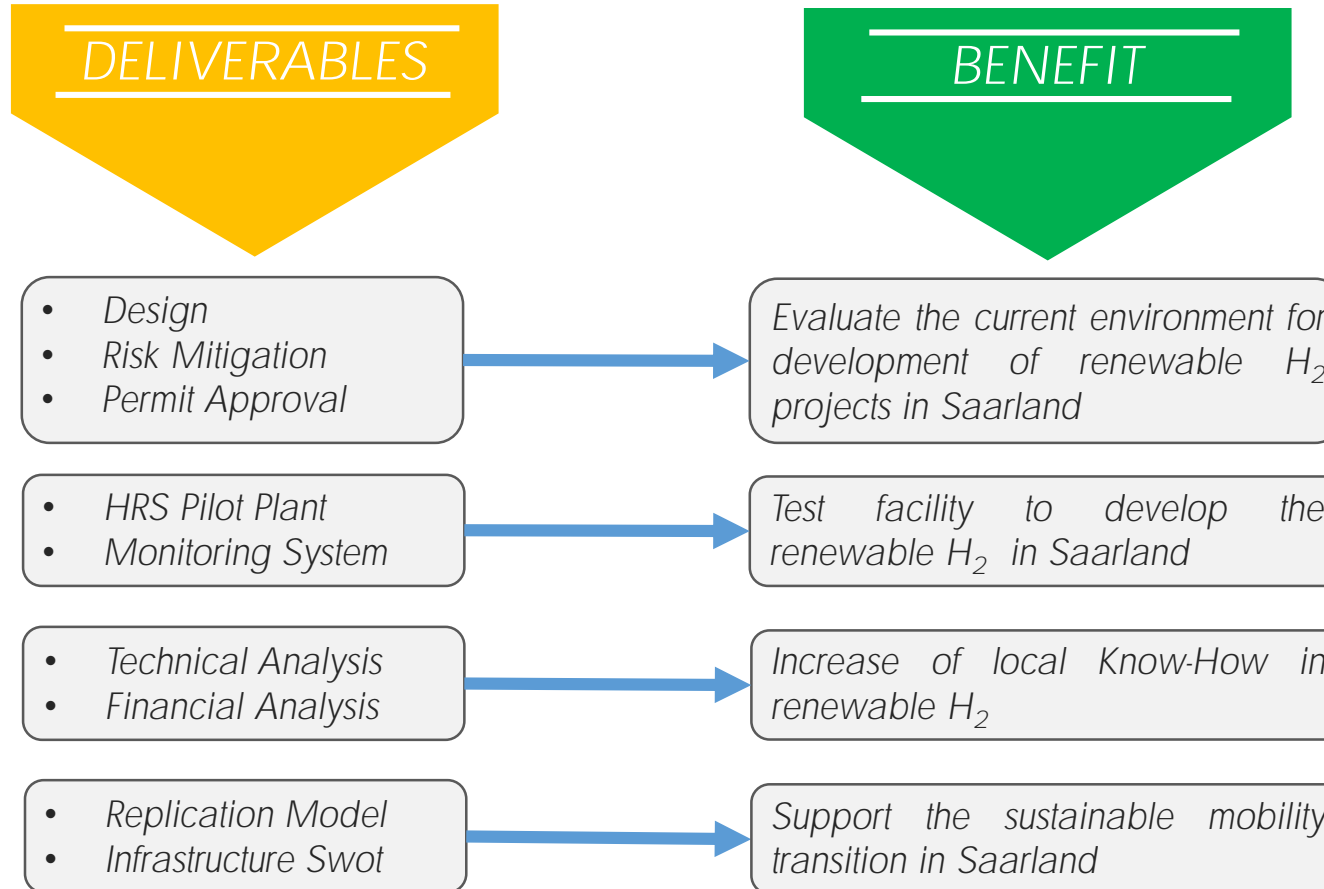

WP.I2 Schedule

Route Ahead

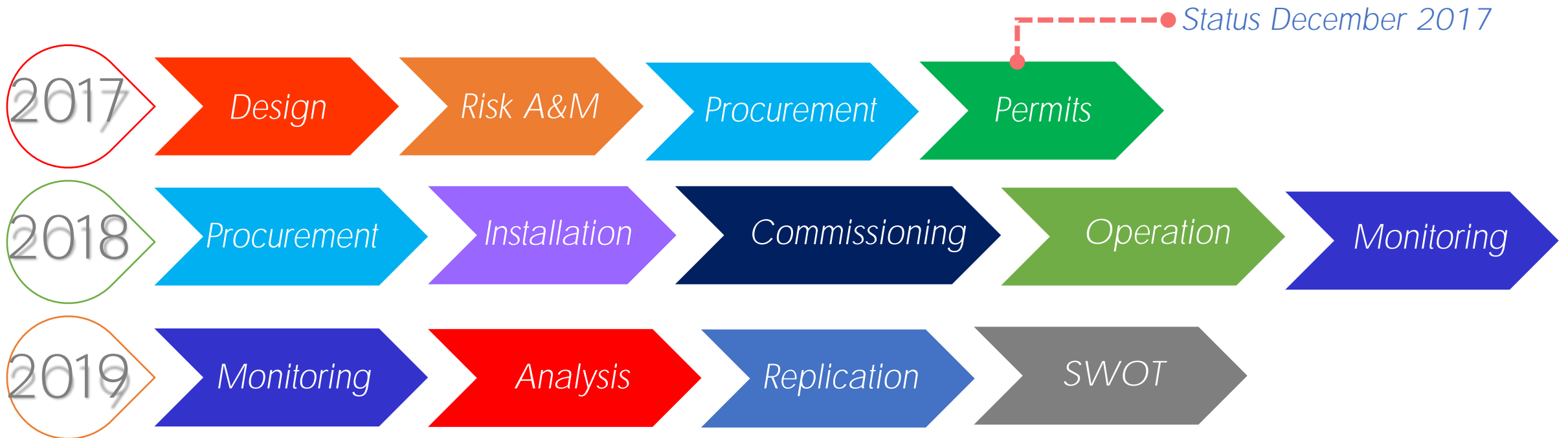

Interreg



EUROPEAN UNION

North-West Europe

GenComm

European Regional Development Fund

Thank You!

Key Note Speaker
Axel Rücker

*Head of Sub-project Component Control & Technology Management,
Department of Hydrogen and Fuel Cells, BMW Group*

Hydrogen for Mobility Applications

Q&A

Coffee Break
15 mins

AGENDA: Block II

16:00 Implementation WPs

- WP.T1 (INSA Rouen)
- WP.T2 (TK Renewables)

16:20 WP Long Term Effects

- WP.LTE (National University of Galway)

16:30 Introduction to Non-Lead Partners (BURN and WIS)

16:40-17:00 Final Words

17:00-18:30 Closing Cocktail

Implementation Work Package, WP.12

Technical Integrated Overall Model of the H₂ Value Chain

Lokmane Abdelouahed



LSPC
Laboratoire
de sécurité
des procédés
chimiques

INSA

INSTITUT NATIONAL
DES SCIENCES
APPLIQUÉES
ROUEN

Overview to WT.I1

The INSA ROUEN Team

Lionel Estel

- *Pr at INSA de Rouen*



Judith Moris Hernandez

- *Recruited on 6 Nov 2017*
- *Master degree*



Lokmane Abdelouahed

- *Dr at INSA de Rouen*



Alejandra Melle Sanchez

- *Recruited on 1 Nov 2017*
- *Master student*
- *1.5 day/week)*



Overview to WT.I1

Integrated Overall Model

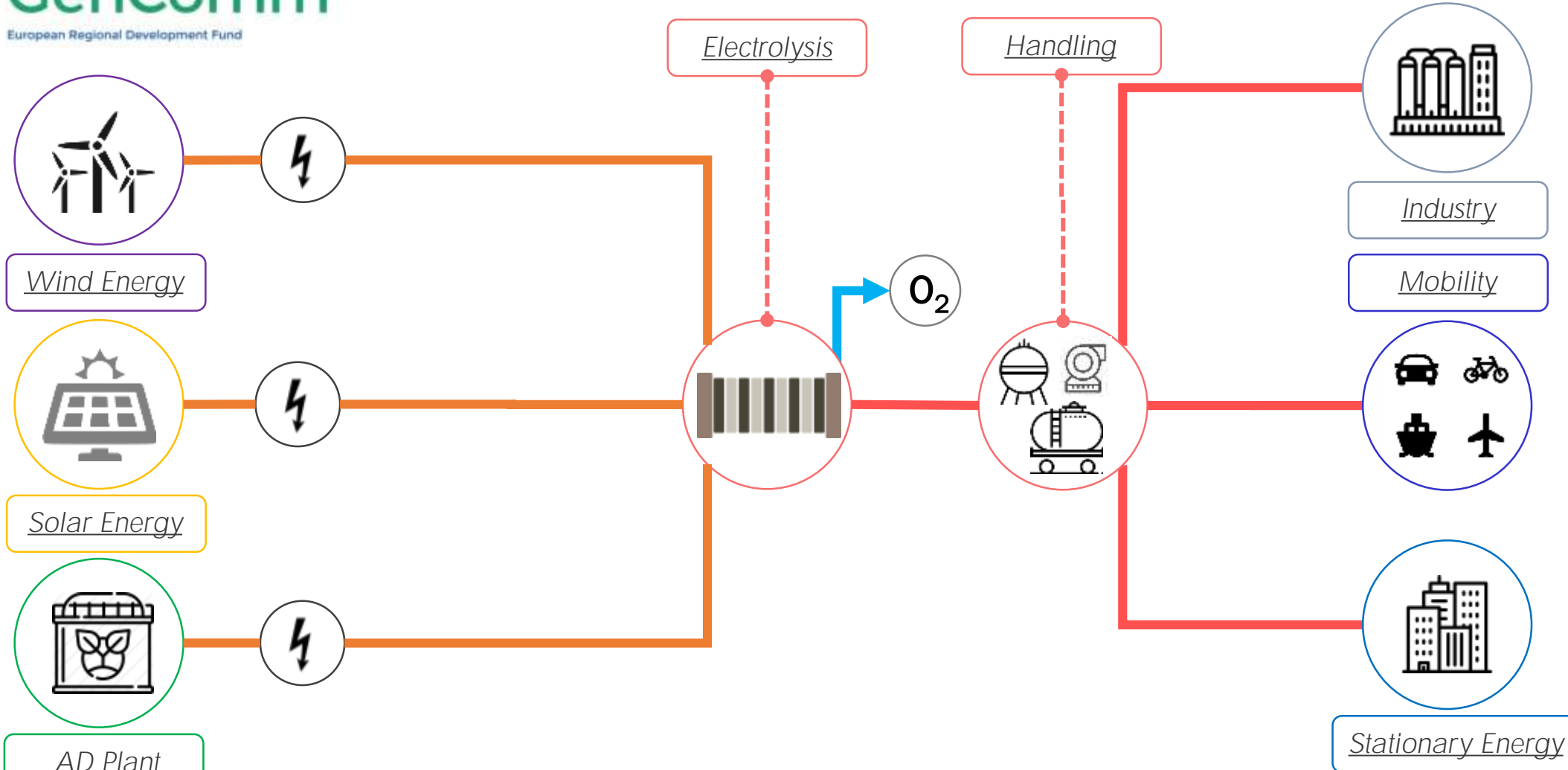

Overview to WT.I1

Model Approach

Modeling under Aspen Plus: Global scheme

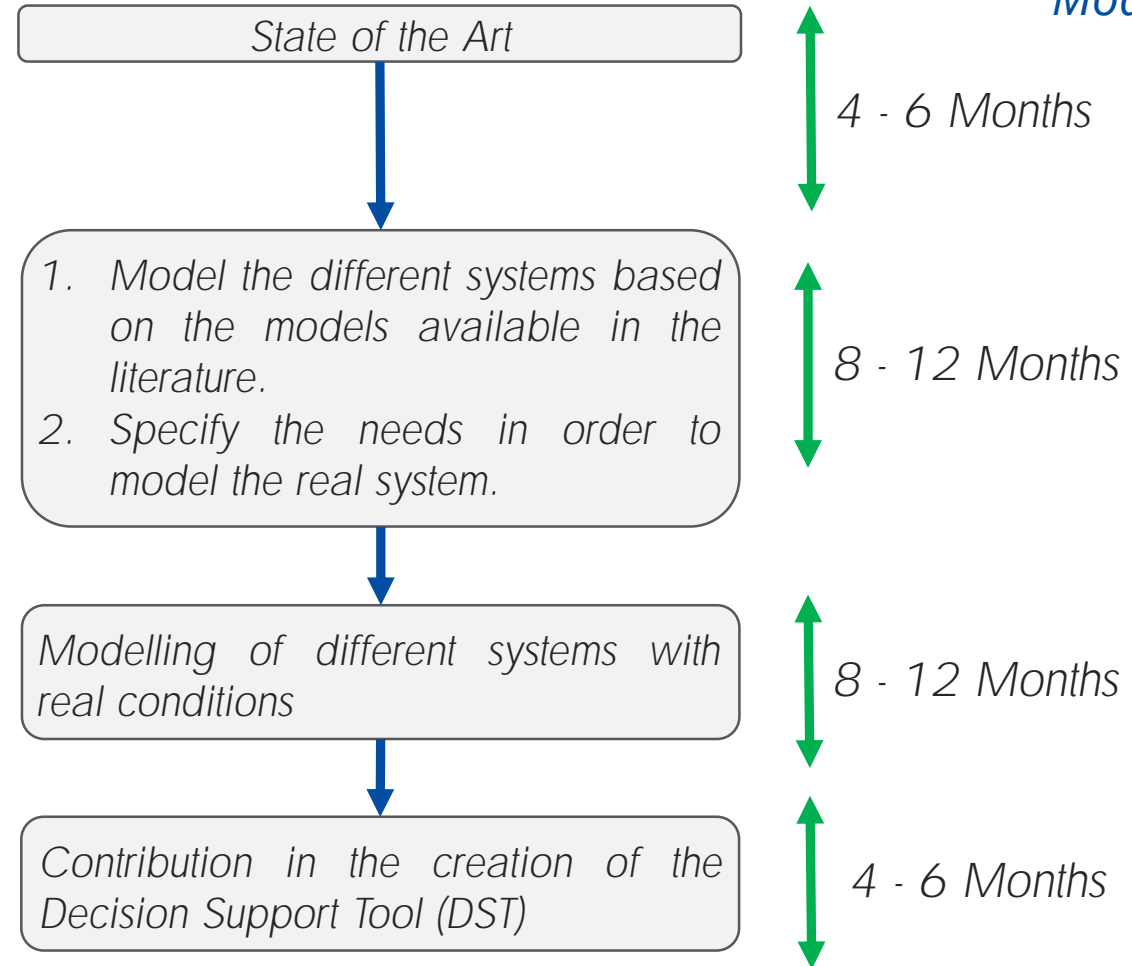

Interreg



EUROPEAN UNION

North-West Europe

GenComm

European Regional Development Fund

Thank You!

Implementation Work Package, WP.T2

Commercial Integrated Overall Model of the H₂ Value Chain
Eibhlin Marsh and Kieran McLaughlin

TK Renewables

- TK RENEWABLES, based in Derry, has been involved in working with renewable energy resources for the last 10 years with particular emphasis on wind technology .
- Staff have already undertaken some research and development work on production of hydrogen using stranded wind resources.
- They have close links with the prestigious Knowledge Innovation Community (KIC) network funded by the EU European Institute of Innovation and Technology (EIT)

The model will comprise of the following elements

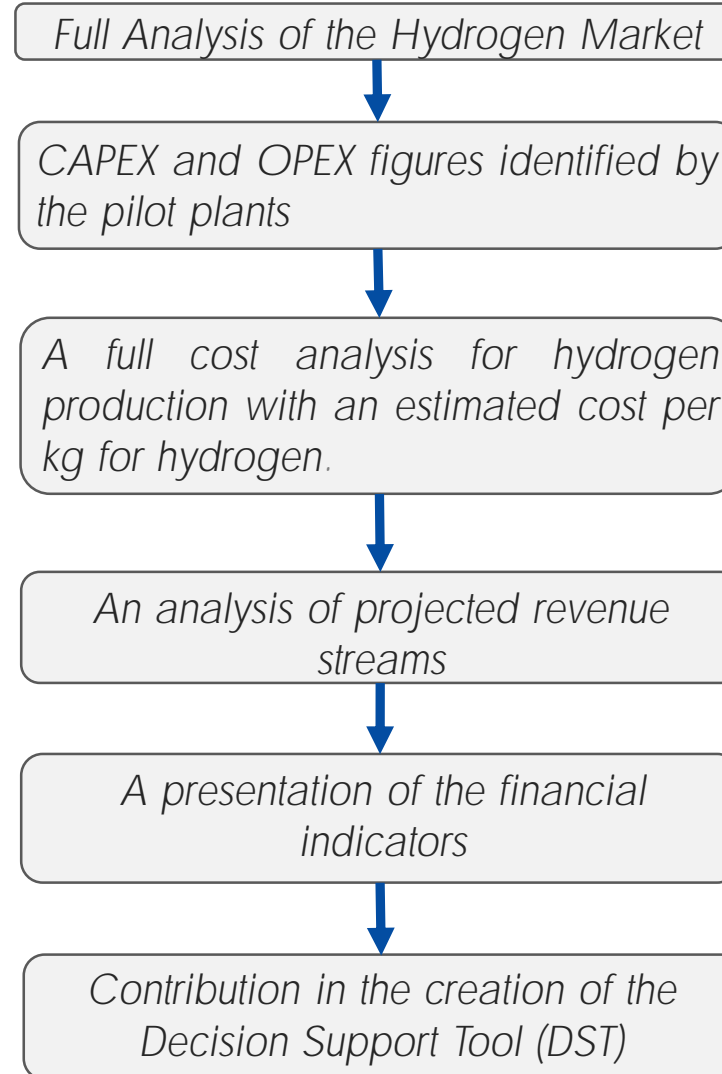

Deliverable 1.1 Market Analysis of Renewable Hydrogen

- *The detailed desk research and analysis has been completed and the report is currently being compiled.*
- *Target date for completion was November 2017 though as it had been difficult to access sufficient data this has been revised to the end of December 2017/start of January 2018*

Interreg



EUROPEAN UNION

North-West Europe

GenComm

European Regional Development Fund

Thank You!

Work Package Long Term Effects, WP.LTE

Decision Support Tool for the H₂ Value Chain

Rory Monaghan



NUI Galway
OÉ Gaillimh



NUI Galway

Description

- One of four constituent universities of the National University of Ireland (NUI).
- Based in Galway, on Ireland's west coast, population 80,000, including 25,000 students.
- Ranked in top 1% of universities globally by QS World University Rankings
- Alice Perry Engineering Building, named for first female Engineering graduate in Ireland or UK, is Ireland's largest engineering education facility.

WP.LTE Team

- Permanent staff
 - Dr Rory Monaghan, School of Engineering - PI
 - Dr Pdraig Molloy, School of Engineering – Co-PI
 - Dr Ed Curry, School of Informatics – Co-PI
- Full-time PhD researcher
 - Mr Arya Gunawan, Mechanical Engineering – H2GO development, CH2F establishment
- Masters researchers (not core GenComm)
 - Mr Wells Tang, M.E. Energy Systems Engineering – Decision-making algorithm
 - Ms Rjaa Ashraf, M.E. Energy Systems Engineering – Synergies with bioenergy
 - Mr Arun Kunnumpurath, M.Sc. Data Analytics – Web-based H2GO elements
- Fourth year researcher (not core GenComm)
 - Mr Pdraig Tobin, B.E. Energy Systems Engineering – Wind resource & H2 demand mapping for Ireland

Long Term Effects, H2GO

Vision for Decision Support Tool Capabilities

Users Questions

Users Questions

DST

How much energy potential can be used for Hydrogen production?

How much Hydrogen can be produced?

How much Hydrogen can be sold?

How much is the investment cost of the project?



Evaluation of energy potential

Production planning

Scenario analysis

Economic assessment

- Energy potential layer
- Criteria Layers

- Annual H₂ production

- Mobility demand
- Heating Demand
- Electrical Demand

- CAPEX
- OPEX
- Net present value (NPV)

Long Term Effects, H2GO

Vision for the DST: Development

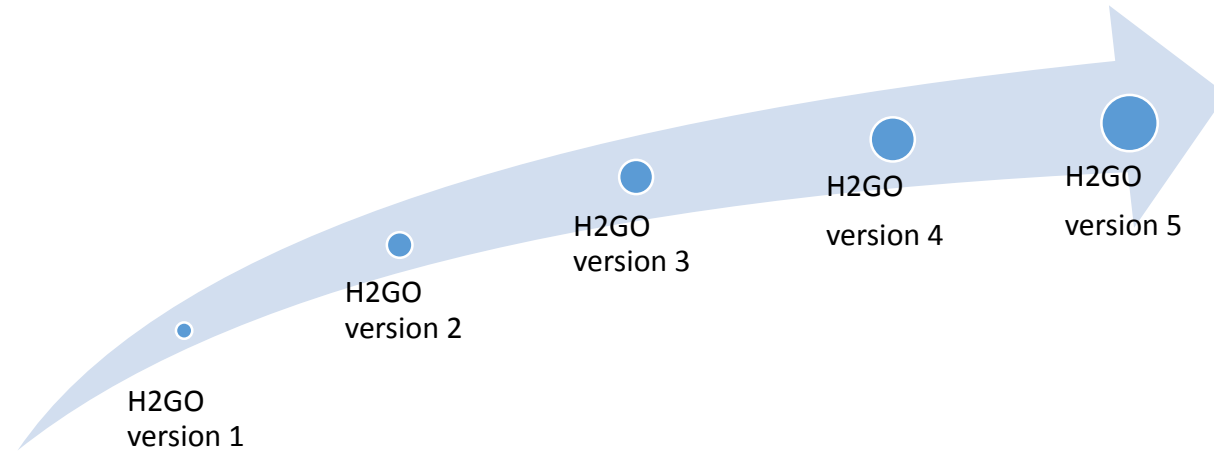

Phase	Version 1	Version 2	Version 3	Version 4	Version 5
Milestone	March 2018	September 2018	March 2019	September 2019	March 2020
Energy source	Wind	Wind, Solar	Wind, Solar	Wind, Solar, Biomass	Solar, Wind, Biomass
Energy product	H ₂ gas	H ₂ gas	H ₂ gas, Methane (P2G)	H ₂ gas, Methane (P2G)	H ₂ gas, Methane (P2G), Synfuel (P2L)
Region	Ireland	Ireland, UK	Ireland, UK France	Ireland, UK France, Germany	North West Europe
Criteria	Limited	Limited	Sufficient	Advanced	Comprehensive

Long Term Effects, H2GO

AHP-Analytical Hierarchical Process

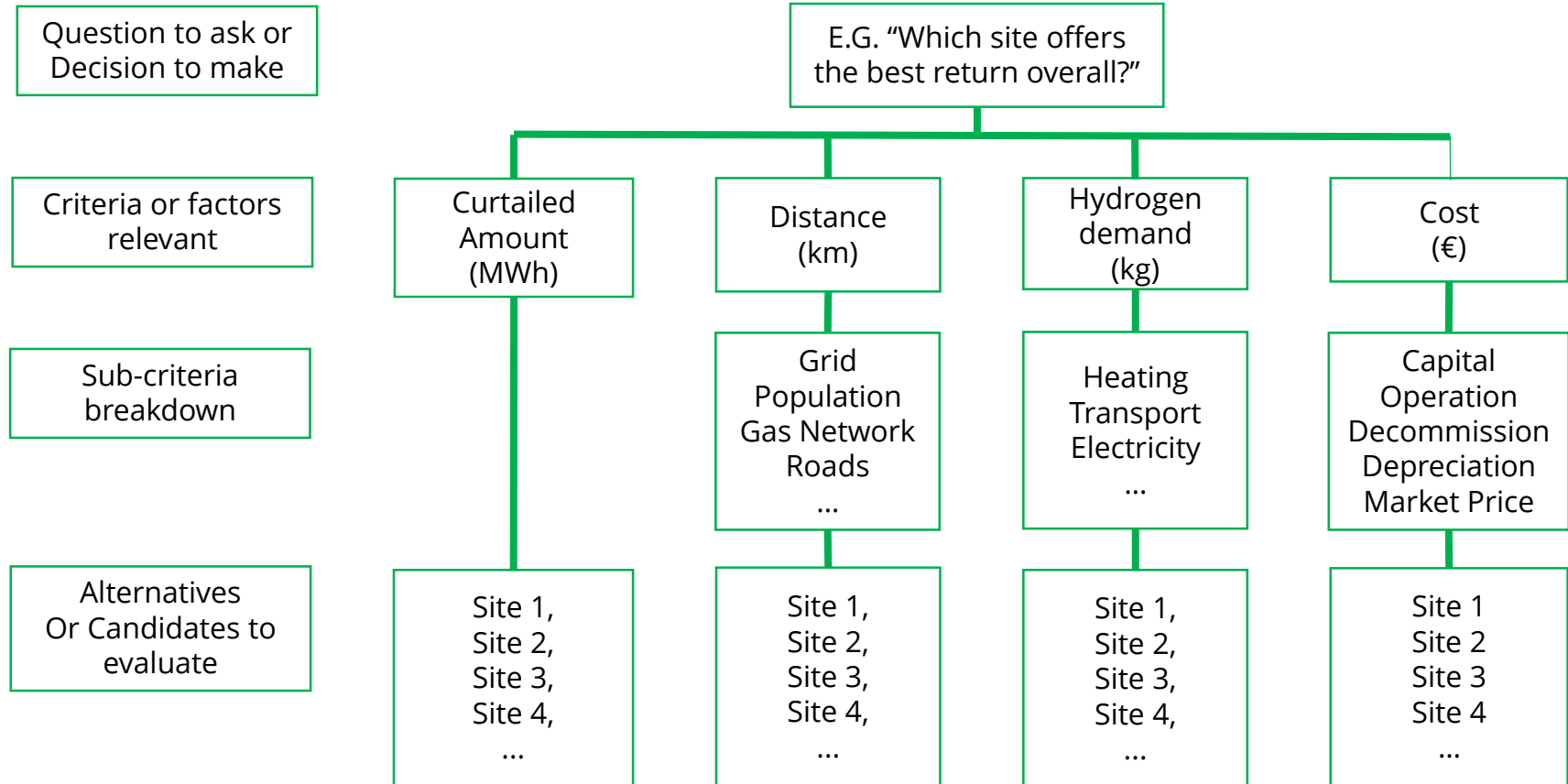

Source: (Evangelos T & Stuart H. Mann 1995)

Long Term Effects, H2GO

Progress: Proposed System Architecture

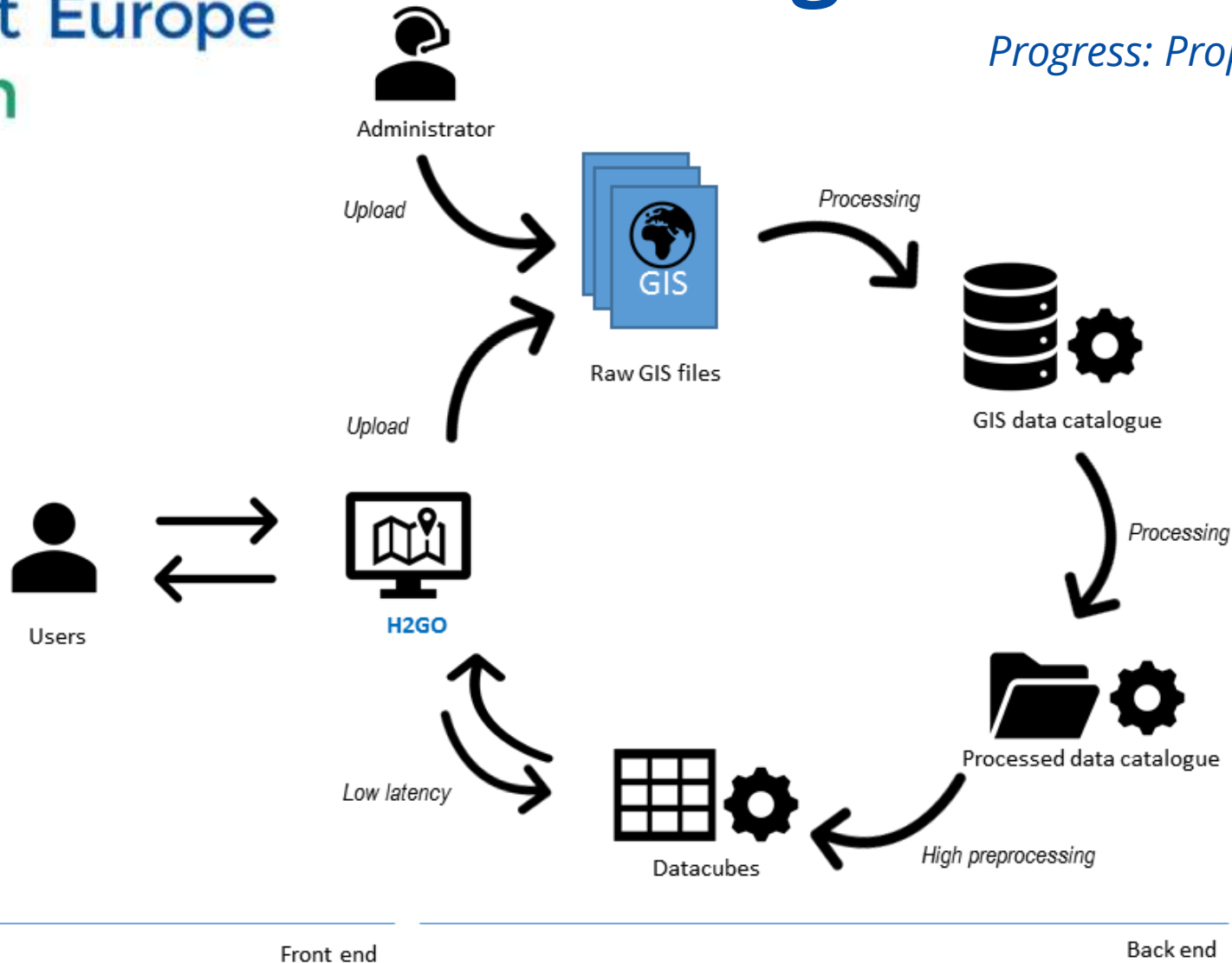

Interreg



EUROPEAN UNION

North-West Europe

GenComm

European Regional Development Fund

Thank You!

Specialist Partners

*BURN, VRIJE Universiteit Brussels
Francesco Contino and Diederik Coppitters*

*Williams Industrial Services
John Bell and Pahvai McKee*





BURN

Organisation Description

Development of flexible, energy-efficient and non-polluting energy conversion technologies.



High-fidelity experimental techniques.

Numerical simulations, robust optimisation and uncertainty quantification.

Research topics:

- Novel combustion technologies;
- Non conventional fuels;
- Robust Optimisation.



Williams Industrial Services

Company Description

- Williams Industrial Services Ltd offers a comprehensive range of factory automation, machine manufacture and facility design consultancy services, encompassed in the following sectors:
 - Water and wastewater
 - Industrial Automation and Control
 - Aerospace and Composites
 - Renewable Energy
 - Support Services
- Established for over 25 years, WIS has more than 170 Engineers and technical support staff.
- Investment in the company is continuing with the development of a highly experienced design and project execution team.

Specialist Partners: BURN

Participation Objectives

The objective is to apply robust optimization on renewable energy storage systems:

- To make sure the hydrogen storage facilities are optimal, taking into account the uncertainty of renewable energy production is vital.*
- Familiarizing with the tools available in the group. Understanding how the optimization techniques work.*
- BURN is ready to optimize all the pilot plants, in a regular (deterministic) and robust way.*

Specialist Partners: BURN

Deterministic Optimization

Deterministic optimization gives the parameter value that corresponds to the optimal objective value:

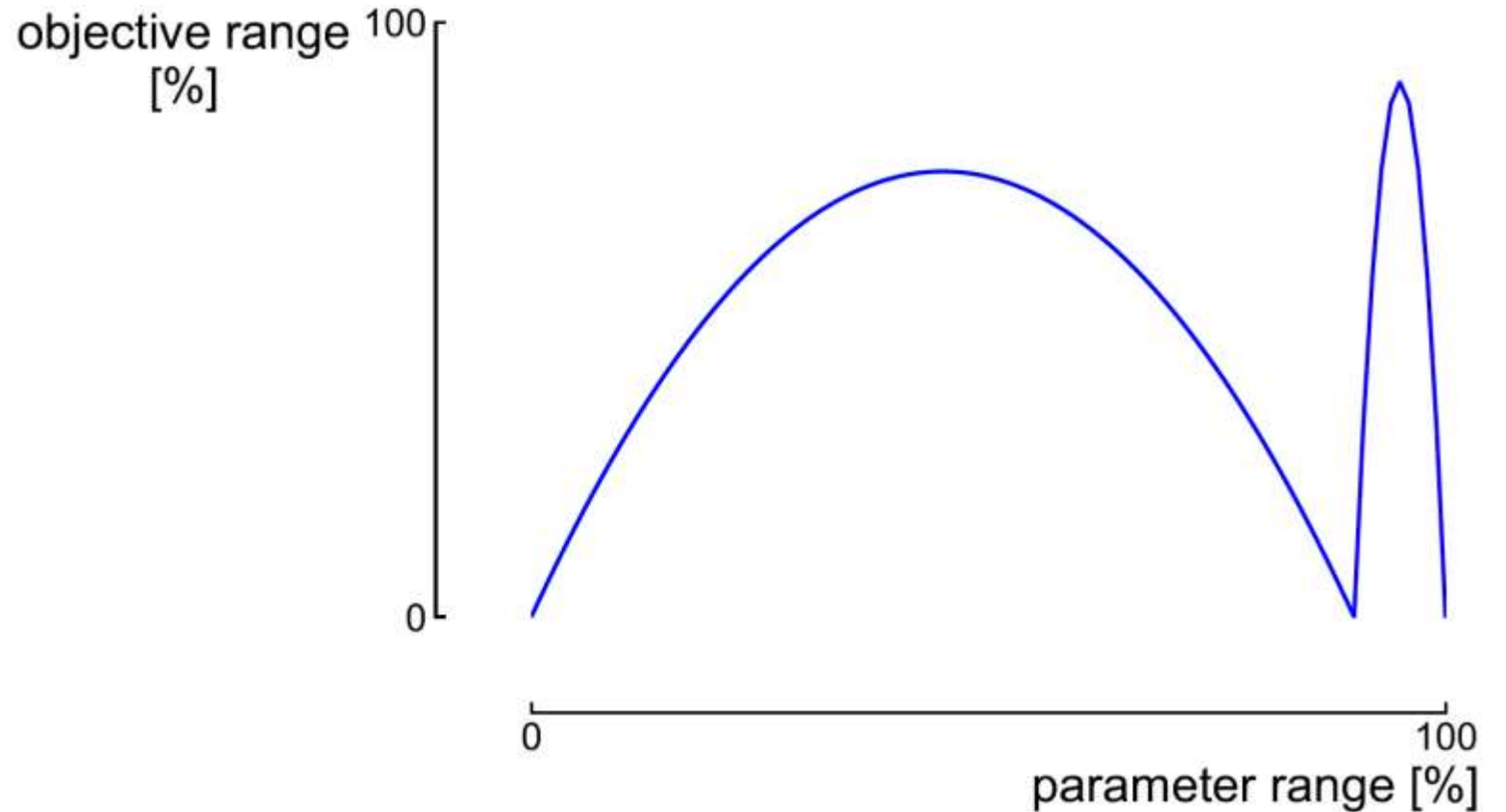

Specialist Partners: BURN

Robust Optimization

Robust optimization results in a parameter range that corresponds to an optimal, robust result:

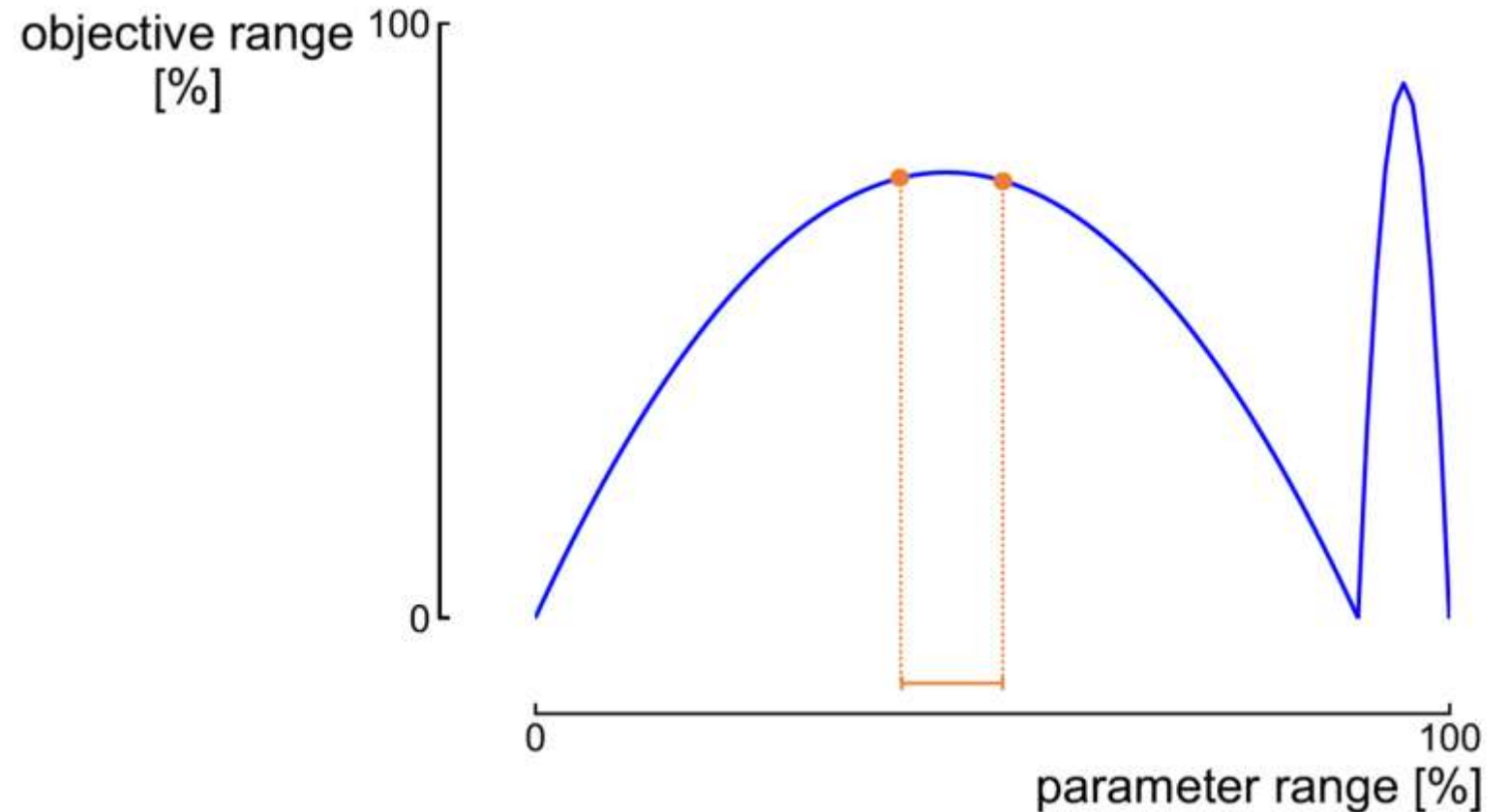

Specialist Partners: BURN

GenComm Optimization

BURN is ready to robustly optimize GenComm:

- *Codes on deterministic and robust optimization are available in the BURN research group*
- *To train on these techniques, the codes are applied on an existing model.*
- *Our MSc students run several projects in parallel to investigate the specific uncertainties related to renewable energy*

Final Words

*Paul McCormack
Project Leader, BelfastMet*



Meet and Greet Cocktail
Thank You for your attendance!